



# SB485, SB232

USB to RS485, RS422 and RS232

industrial converters

with galvanic isolation



# SB485, SB232

## Datasheet

Created: 1/19/2005

Last update: 5/18/2005 15:22

Number of pages: 20

© 2011 Papouch s.r.o.

---

## Papouch s.r.o.

Adresa:

**Strasnicka 3164/1a  
102 00 Prague 10**

Telefon:

**+420 267 314 267**

Fax:

**+420 267 314 269**

Internet:

**www.papouch.com**

E-mail:

**info@papouch.com**



**CONTENT**

Basic information .....	4
Description.....	4
Application .....	4
Features .....	4
Connection and installation .....	5
Connection .....	5
SB485: Installation for RS485 .....	6
SB485: Installation for RS422 .....	6
Installation under Windows XP .....	7
Procedure .....	7
Changing the COM port number .....	13
Manual installation of the driver.....	13
Uninstalling .....	13
Temporarily removing the converter.....	13
Installation in Linux Operating System.....	14
Updates for Drivers .....	14
Setup of SB485.....	14
Line termination and idle mode .....	14
Indication .....	15
Technical parameters .....	16
Available designs .....	17

## BASIC INFORMATION

### Description

The SB485 and SB232 converters have been designed to convert USB to RS485, RS422 or RS232 serial lines. A virtual serial port is created in the PC to access the serial line. The properties of the RS4xx lines are configurable by switches on the SB485 converter. LEDs indicate power on and data transfer in both directions.



*Fig. 1 – After connecting, “a virtual serial port” is created in your PC. Within the system it acts like a standard serial COM port.*

### Application

- RS232 serial port for laptops
- PC protection against overvoltage
- Interruption of ground loops

### Features

- Conversion of USB to RS232, RS485, RS422 and RS422 Multimaster industrial lines
- Setup of the RS485, RS422 or RS422 Multimaster lines via switches on the converter
- Access to the serial line via a virtual serial port
- Automatic data flow switching without delay
- Galvanic isolation of USB from the serial line
- Data transfer rate up to 1 Mb/s
- User-configurable termination of the RS485/RS422 line
- Indication of power on and data flow by three indicators (ON, TXD, RXD)
- A unique serial number that allows the user – via USB-HUB – to connect multiple converters together with other USB devices
- Connection to a PC via standard USB cable supplied with the converter
- Mountable on DIN 35 mm rail and on the wall
- 5 V power supply from the USB interface
- Dimensions 54 × 62 × 24 mm

## CONNECTION AND INSTALLATION

### Connection

The **USB bus** is connected to the PC via the supplied cable terminated with a USB connector.<sup>1</sup>

**SB485S:** The **RS485/422** line is connected via a slip-on bus bar located on the side of the device. The connection of the bus bar is illustrated in Figure 2.



Fig. 2 – bus bar on SB485S

**SB485C:** The **RS485/422** line is connected via a D-SUB 9M connector (Cannon 9 male plug). The connection is illustrated in Figure 3.

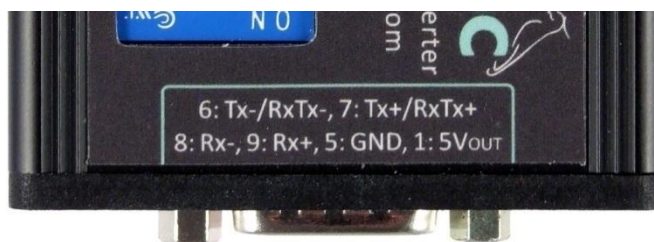

Fig. 3 – connector on SB485C

**SB232:** The **RS232** line is connected via a D-SUB 9M connector (Cannon 9 male plug). The connection is illustrated in Figure 4. (The connection is the same as on a PC.)

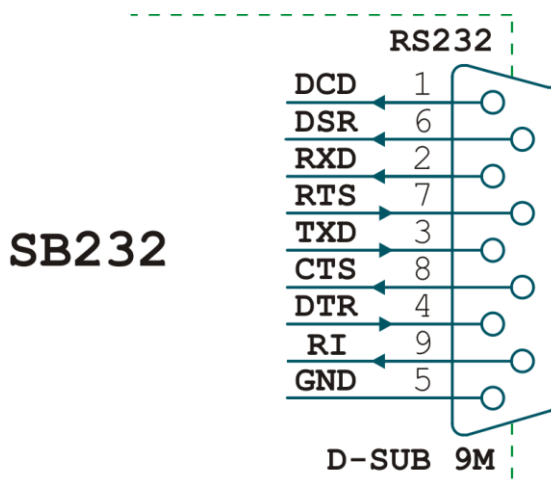

Fig. 4 – connection of the RS232 connector

<sup>1</sup> A standard USB cable (type A-B) for connecting devices.

**SB485: Installation for RS485**

Installation of the SB485 converter for communication via RS485:

- 1) Connect the converter to a PC and install the driver as described on page 7.
- 2) Move the **SW3** switch to position **OFF** and **SW4** to position **ON**.
- 3) Connect the RS485 wires as illustrated in Table 1.

Wire	Note
RxTx+ (A)	bi-directional data ⇔
RxTx- (B)	bi-directional data ⇔
GND	signal ground – possible connection of shielding

Tab. 1 – Connection of RS485

- 4) In case the convertor is located at the end of the line, connect terminating resistors using the TERM485 connector. Consider the connection of resistors defining the idle state.

**SB485: Installation for RS422**

Installation of the SB485 converter for communication via RS422:

- 1) Connect the converter to a PC and install the driver as described on page 7.
- 2) Move the **SW3** switch to position **ON**.
- 3) Move the **SW4** switch according to the method of using the RS422 line. If the RS422 line is only used to interconnect two devices or if all connected devices transmit data only in the direction to the SB485 converter, move the SW4 switch to position **OFF**. This setting is **standard** – the RS422 line driver in the SB485 converter is permanently on making the line more resistant to interference

If another device is to transmit via the line together with the SB485 converter (“**Multimaster**” mode), the driver in the converter must be switched off. The “Multimaster” mode is enabled by moving the SW4 switch to position **ON**.

- 4) Connect the RS485 wires as illustrated in Table 2.

Wire	Note
RxTx+ (A)	⇒ data from the SB485 converter (or from the PC)
RxTx- (B)	⇒ data from the SB485 converter (or from the PC)
Rx+ (A')	⇐ data into the SB485 converter (or into the PC)
Rx- (B')	⇐ data into the SB485 converter (or into the PC)
GND	signal ground – possible connection of shielding

Tab. 2 – Connection of RS422

- 5) In case the convertor is located at the end of the line, connect terminating resistors using the TERM422 connector. For “Multimaster” mode, consider the connection of resistors defining the idle state.

## Installation under Windows XP

### Procedure

(The following procedure is given for SB485. SB232 is installed in the same way.)

A driver must be installed for the SB485 converter. Connect the SB485 converter to USB port of a switched-on PC with an MS Windows operating system. The green indicator on the converter is on and after a while (in which the Windows OS detects the new device), the screen shown in Fig. 5 is displayed.<sup>2</sup>



Fig. 5 – Found New Hardware Wizard

Select "Install from a list or specific location." Select the "Next" button.

<sup>2</sup> If the operating system has not detected the new device, you can activate the driver installation manually – cf. the "Manual installation of the driver" on p. 14.

In the screen of Fig. 6 choose "Search for the best driver in these locations" and specify the path (A:\). Put the supplied floppy disk into the floppy-disk drive and select "Next" again. (You can also download the drivers from [www.papouch.com](http://www.papouch.com).)

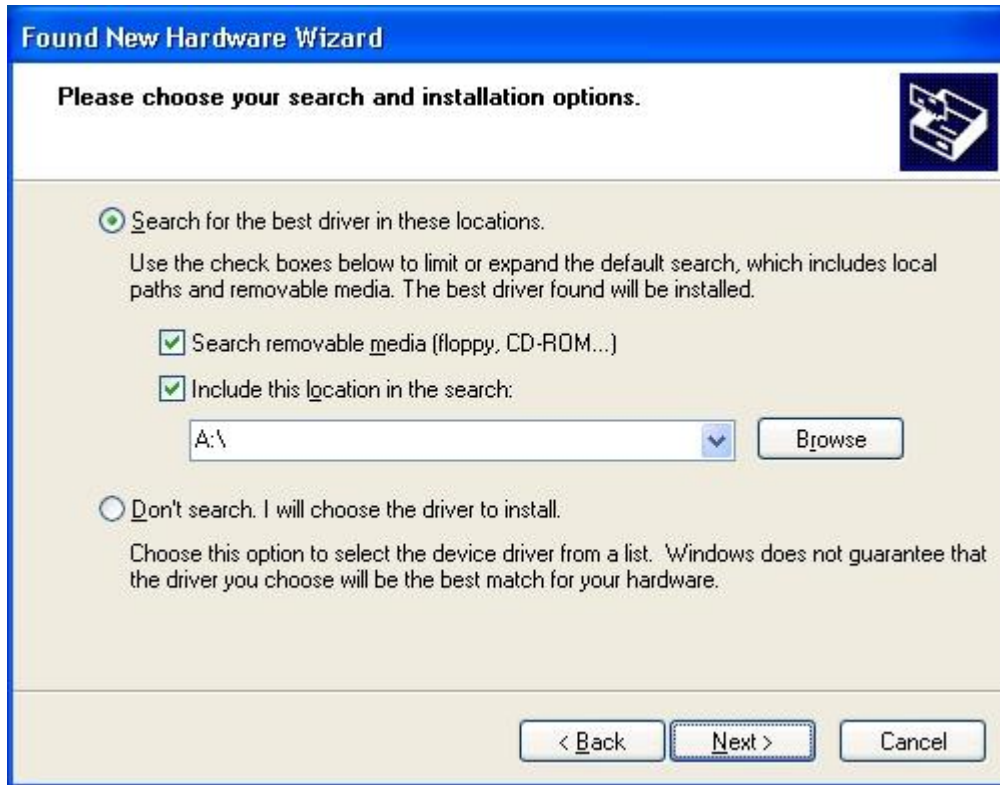

Fig. 6 – Driver Location

In the dialog box of Fig. 7 select the "Continue Anyway" button.



Fig. 7

Select the "Finish" button. You have successfully completed the first part of the installation now.



Fig. 8

In the second part, a driver is installed for the virtual serial port via which the RS485 or RS422 line can be accessed.

The screen shown in Fig. 9 is displayed. Select "Install from a list or specific location" as before. Select the "Next" button.



Fig. 9 – Found New Hardware Wizard

The screen shown in Fig. 6 is displayed. In the screen for driver selection, choose "Search for the best driver in these locations" and specify the path (A:\). Put the supplied floppy disk into the floppy-disk drive and select "Next" again.

In the dialog box of Fig. 10 select the "Continue Anyway" button.



Fig. 10

In the dialog box of Fig. 10 select the "Next" button. At this moment, both drivers for the SB485 converter and for the virtual serial port have been successfully installed.



obr. 11 – Finish

The "Device Manager" can be viewed as follows (the actual procedure may be slightly different according to the Windows version): Right click the "My Computer" icon and choose "Properties" in the dropdown menu. Select the "Hardware" tab and the "Device Manager" button (cf. the dialog box shown in Fig. 12).<sup>3</sup>

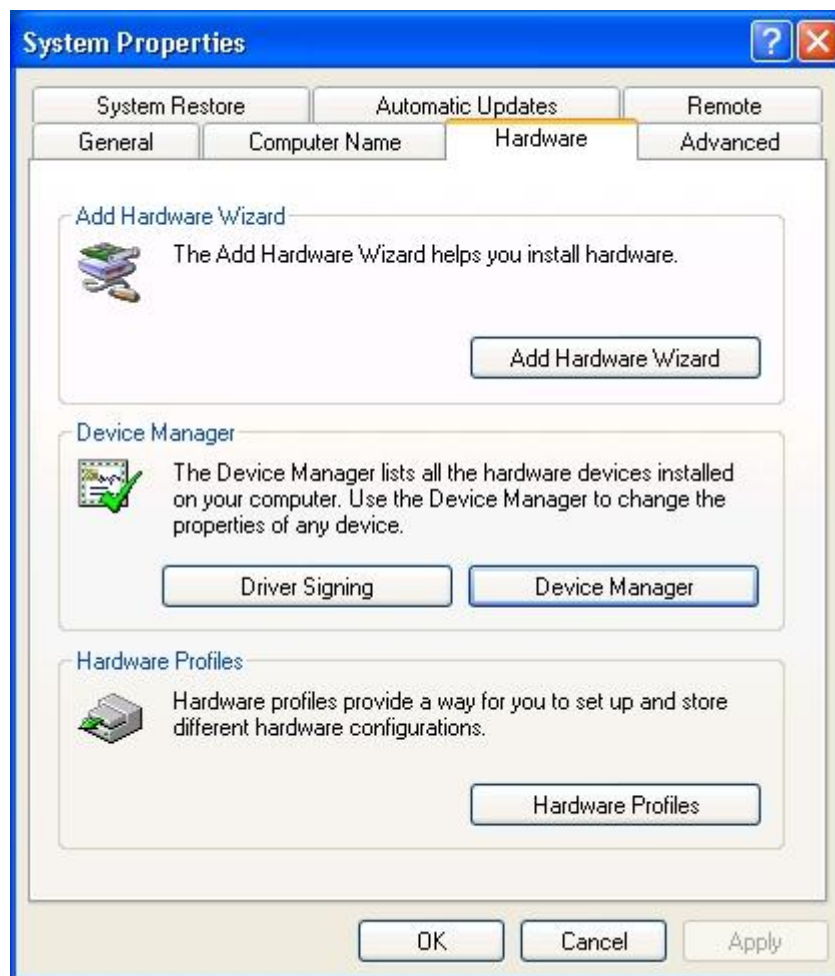

Fig. 12 – System Properties

<sup>3</sup> Alternatively, click the "Start" menu and go Control Panel / System, tab "Hardware," button "Device Manager"

In the "Ports (COM & LPT)" item of the "Device Manager," you can see the COM port on which the RS485 or RS422 line is accessible. Set the number of this port in your application. The SB485 converter is shown in the "Universal Serial Bus controllers." (cf. the dialog box shown in Fig. 13)

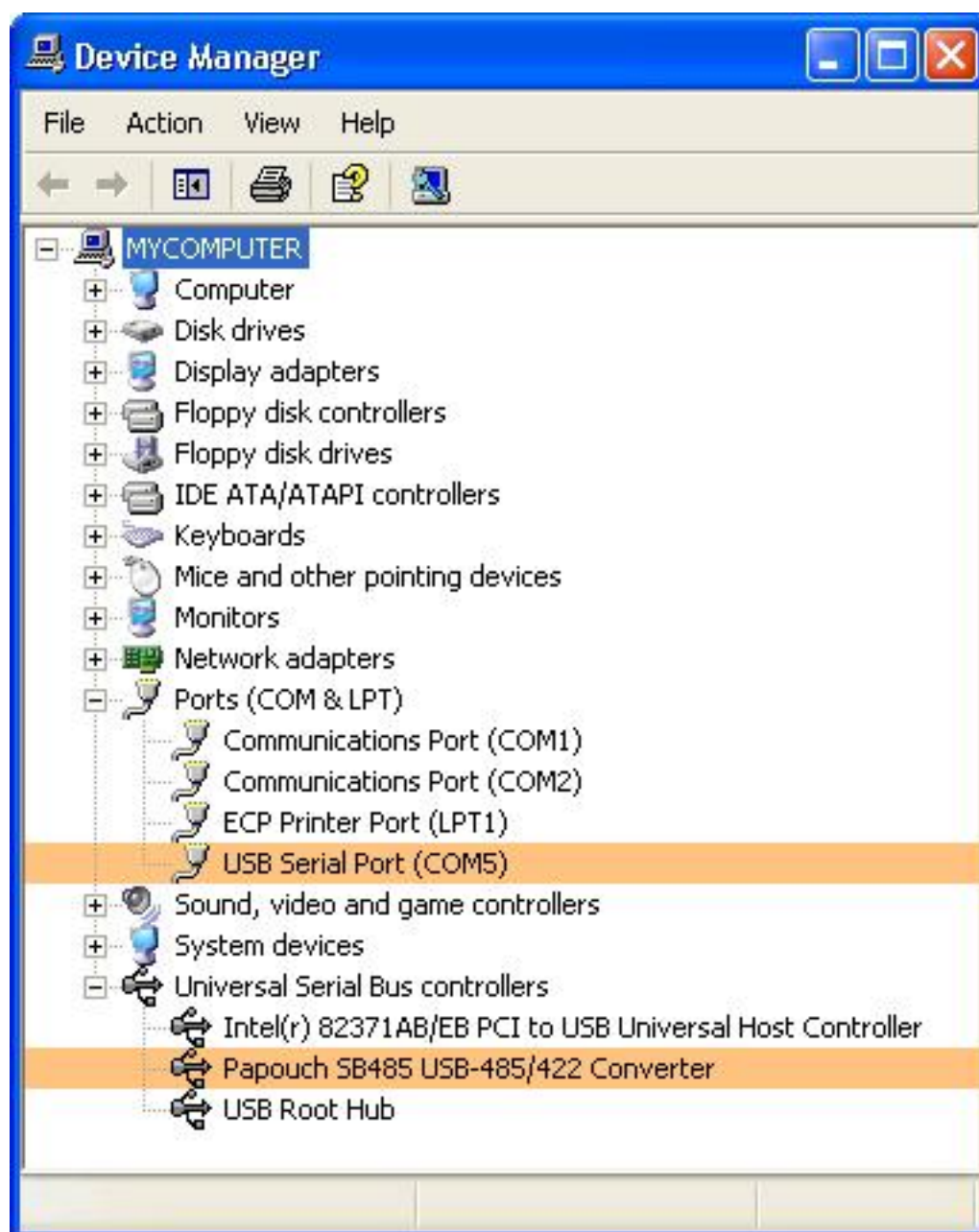

Fig. 13 – Device Manager

## Changing the COM port number

---

If the automatically assigned number of the COM port is unsuitable, you can change it. Click on the "Ports (COM & LPT)" item of the "Device Manager." Right-click the "USB Serial Port" and choose "Properties." Select the "Port Settings" tab and the "Advanced..." button. Here you can select the "Com Port Number."

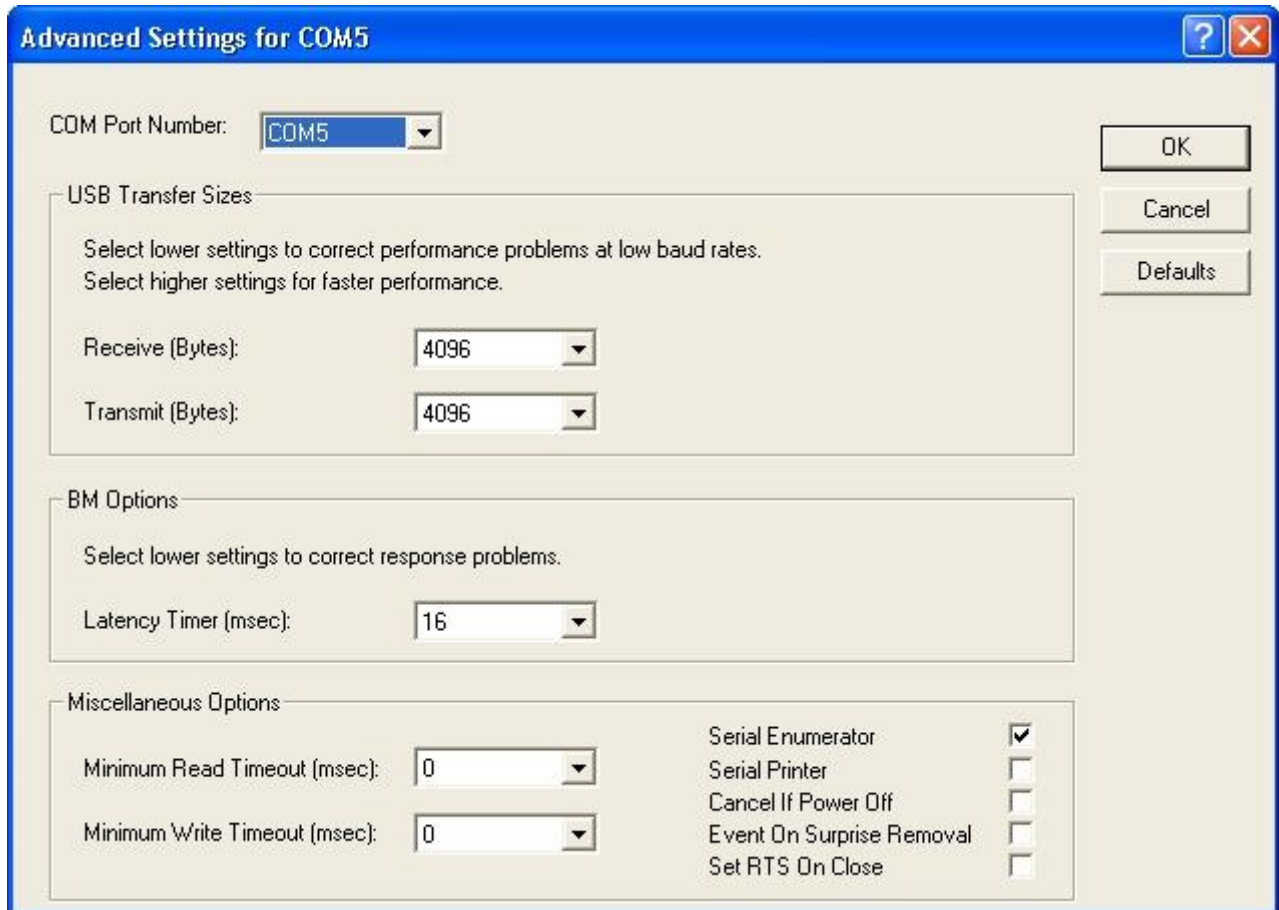

Fig. 14 – Changing the COM port number

Confirm the change by the "OK" button.

## Manual installation of the driver

---

If the system does not start searching for the driver automatically after connection of the new device, you can proceed as follows: Open the "Control Panel" (in the "Start" menu, go Settings / Control Panel), choose the "Add Hardware" item and select the "Next" button. When installing the driver, insert the floppy disk and continue as described above.

## Uninstalling

---

If you wish to completely uninstall the converter, it is not sufficient to remove the port from the system. Disconnect the SB485 converter from the PC and uninstall the driver using the "Add or Remove Programs" item in the "Control Panel."

## Temporarily removing the converter

---

When the SB485 converter is disconnected, the COM port will disappear from the "Device Manager." After reconnecting the converter, the port will be displayed in the Device Manager again, with the original settings.

## Installation in Linux Operating System

Linux drivers can be downloaded from <http://www.ftdichip.com> .

## Updates for Drivers

Since drivers are under constant development along with the development of operating systems, you can download the current version from our website <http://www.papouch.com/>, for sections dedicated to the convertor SB485 or SB232.

## SETUP OF SB485

The SB485 converter is set using six switches on the front panel (Fig. 15).



Fig. 15 – switches on the front panel

The type of the required communication line is set by switches SW3 and SW4 according to the following table:

SW3	SW4	line
OFF	ON	RS485
ON	OFF	RS422
ON	ON	RS422 – Multimaster

## Line termination and idle mode

### TERM485

This device connects the impedance termination of RS485 or RS422 on the transmitter's side. It prevents signal from bouncing at the line ends. These resistors should be connected at both ends of the communication line.

### TERM422

This device connects the impedance termination of RS422 on the receiver's side. It prevents signal from bouncing at the line ends. These resistors should be connected at both ends of the communication line.

### BIAS485

This device connects the resistors which define the idle mode of RS485 or RS422 on the transmitter's side. They determine the idle-status levels of the communication line. (More detailed information can be found in the section "Idle mode" on page 15.)

**Idle mode**

When communicating on RS485 or RS422 multimaster, there may be a no-transmission status (all lines are in the receiving mode). If this is the case, the status of the line is undefined and it is extremely sensitive to any induced voltage (interference), which is deemed incoming signals. Therefore an idle mode should be defined by connecting suitable resistors to a line point. If the line is long, the best point is at the SB485 end-of-line modules or equipment.

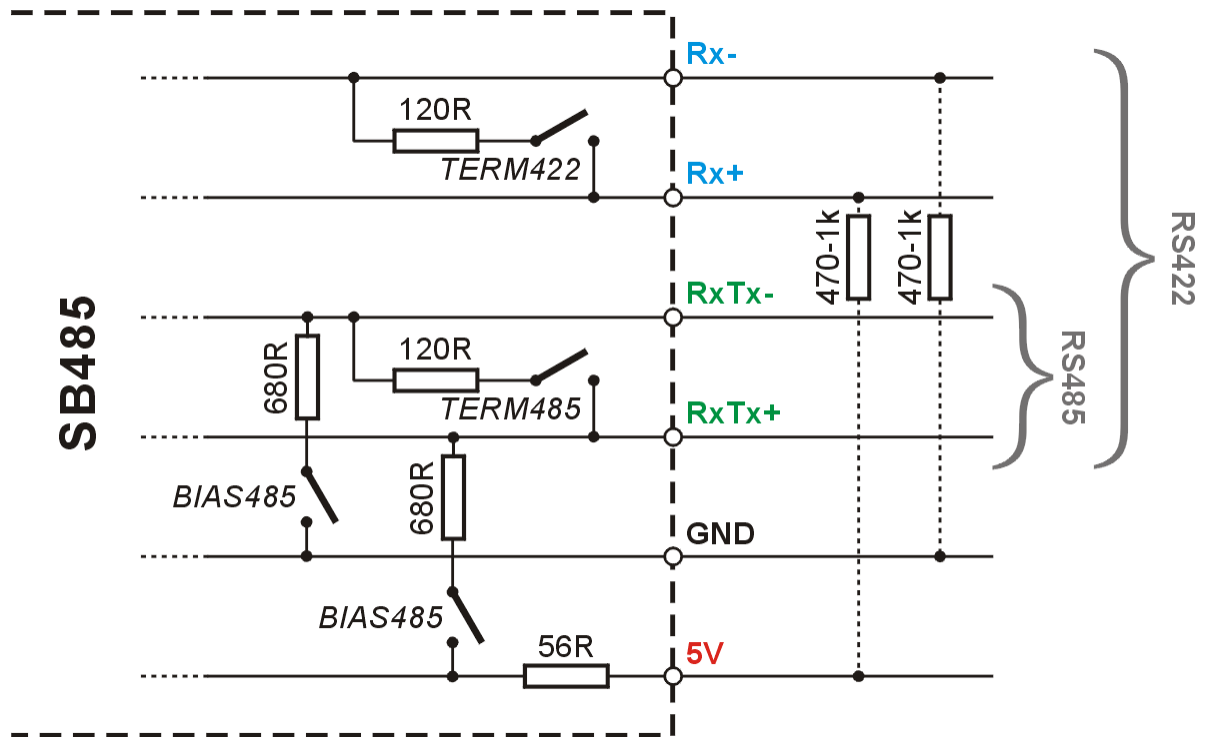

Fig. 16 – Connection of external resistors

With the SB485 converter, build-in resistors can be used, connected by the BIAS485 switches; if a definition of idle mode of RS422 receiver’s side is required, external resistors may be connected directly to the RS485 connector Fig. 16. For long lines, the resistor values should be larger and the termination should be connected simultaneously. GND can also be used for connection of the cable shielding contact.

**INDICATION**

The device is equipped with three indicator lights.

- ON (green).....lit when power supply voltage is detected.
- TXD (yellow) .....indicates data transmission from USB to RSxxx
- RXD (yellow).....indicates data transmission from RSxxx to USB

## TECHNICAL PARAMETERS

### USB

Specification.....USB 1.1 (USB 2.0 compatible)

Connector .....type B

### RS485/422 – SB485

Modes .....RS485, RS422, RS422 Multimaster

Maximum speed.....1 Mb/s

Terminating resistors.....120  $\Omega$

Resistors defining the idle state .....680  $\Omega$

Maximum number of connected devices.....31 (according to the standard of RS485)

Overvoltage protection .....yes, 6.5 V transils

5 V connector .....yes, to connect external resistors;  
maximum load: 10 mA

Connector – SB485S .....slip-on bus bar

Connector – SB485C .....D-SUB 9M (Cannon 9; male plug)

Temperature range .....-40 to +85 °C

### RS232 – SB232

Signals of RS232 .....all according to the specifications of RS232:  
TxD, RxD, RTS, CTS, DTR, DSR, DCD, RI

Maximum input voltage at the interface of RS232..  $\pm 30$  V

Short-circuit protection of RS232 .....typically for 25 mA

Maximum speed.....120 kbps (standard)  
(possible to order up to 1 Mbps)

Connector .....D-SUB 9M (Cannon 9; male; like on a PC) <sup>4</sup>

Temperature range .....-40 to +85 °C

### Other parameters

Galvanic isolation of serial line .....yes

Supply voltage .....5 V (from the USB interface)

Current consumption from USB .....typically 45 mA

Degree of protection.....IP 30

Weight.....75 g

Box material .....anodized aluminium

Dimensions (without connector) .....54 × 62 (55) × 24 mm

<sup>4</sup> The connection is illustrated in Figure 4 on page 5.

## Available designs

### Serial line

- RS485/RS422 with a bus bar (**SB485S**)



Fig. 17 – Design with RS485/422 serial line (SB485S)

- RS485/RS422 with D-SUB 9M connector (**SB485C**)



Fig. 18 – Design with RS485/422 serial line (SB485C)

- RS232 (**SB232**)



Fig. 19 – Design with RS232 serial line (SB232)

### Assembly

- No mounting clip (*standard design*)
- With a clip for DIN 35 mm rail



Fig. 20 – SBxxx with a clip for DIN 35 mm rail

- With a wall mounting bracket (hole pitch is 73 mm)



*Fig. 21 – SBxxx with a wall mounting bracket*

Do not hesitate to contact us in case of any other requirements concerning the design and functions of the SB485 and SB232 modules.



# Papouch s.r.o.

Data transmission in industry, line and protocol conversions, RS232/485/422/USB/Ethernet/GPRS/WiFi, measurement modules, intelligent temperature sensors, I/O modules, and custom-made electronic applications.

Adresa:

**Strasnicka 3164/1a  
102 00 Prague 10**

Telefon:

**+420 267 314 267**

Fax:

**+420 267 314 269**

Internet:

**[www.papouch.com](http://www.papouch.com)**

E-mail:

**[info@papouch.com](mailto:info@papouch.com)**

